

**Doers Window**  
MANUFACTURING  
4901 Oak Fair Blvd., Tampa, FL 33610

# 9500-3 Slider XOX w/ Nailing Fin "NON-IMPACT"

### GENERAL NOTES

1. This product anchoring drawing has been evaluated and is in compliance with the 5th Edition (2014) Florida Building Code (FBC) excluding the "High Velocity Hurricane Zone" (HVHZ). See the Certification Agency Certificate for sizes, specifications & ratings.
2. Product anchors shall be as listed and spaced as shown on details. Anchor embedment to base material shall be beyond wall dressing or stucco.
3. When used in areas requiring wind borne debris protection this product is required to be protected with an impact resistant covering that complies with Section 1609.1.2 of the FBC.
4. Site conditions that deviate from the details of this drawing require further engineering analysis by a licensed engineer or registered architect.

TABLE OF CONTENTS	
SHEET#	DESCRIPTION
1	Typical elevations, design pressures & general notes
2	Vertical & horizontal cross sections
3	Vertical & horizontal cross sections
4	Buck & frame anchoring
5	Components
6	Bill of materials and glazing details

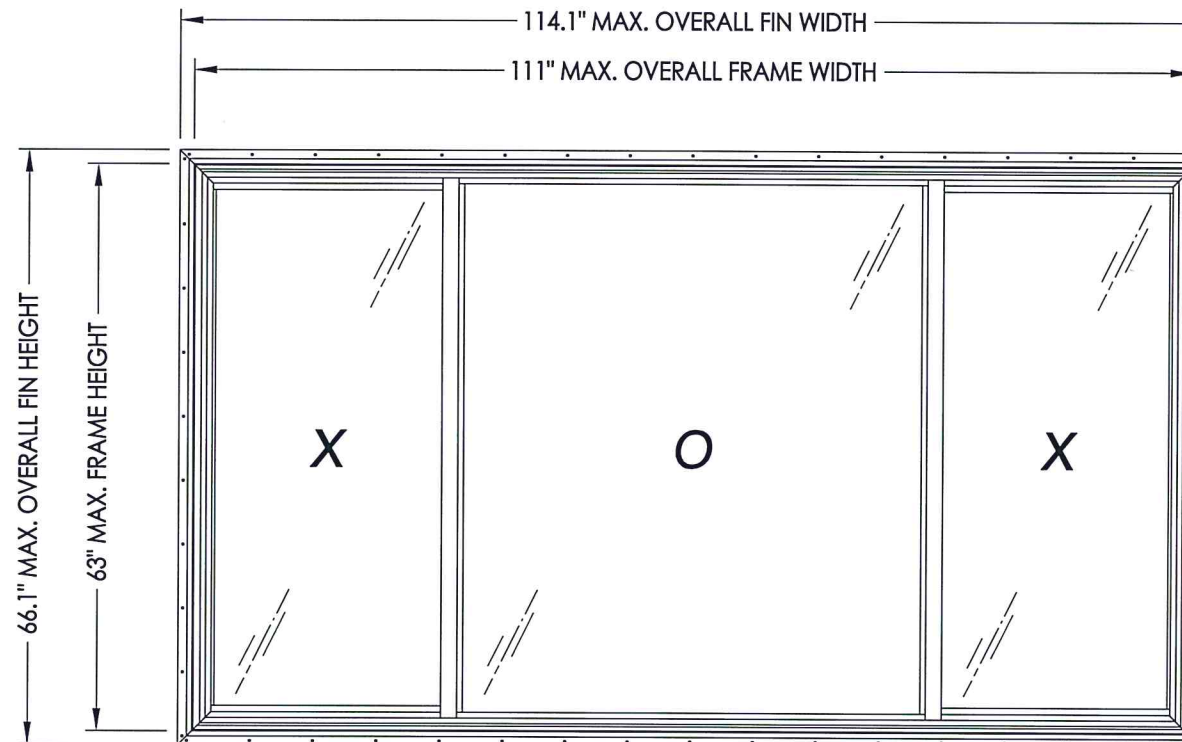

MAX. OVERALL FIN DIMENSION	MAX. OVERALL FRAME DIMENSION	MAX DAY LITE DIMENSION (OPERABLE)	MAX DAY LITE DIMENSION (FIXED)	GLASS TYPE	DESIGN PRESSURE (PSF)	
					POS.	NEG.
114.0" X 66.0"	111.0" X 63.0"	25.0" X 57.25"	51.0" X 58.5"	G1	+45.0	-45.0

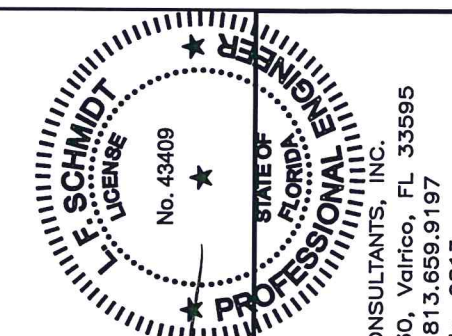

Documents Prepared By:  
Lyndon F. Schmidt  
P.E. No. 43409

*RW* BUILDING CONSULTANTS, INC.  
P.O. Box 230, Valrico, FL 33595  
Phone No.: 813.659.9197  
FBPE C.A. No. 9813

PRODUCT: Doers

PART OR ASSEMBLY:  
TYPICAL ELEVATION, DESIGN PRESSURES & GENERAL NOTES

NO.	DATE	REVISIONS
1	6/25/15	UPDATE TO 5TH ED. (2014) FBC

DATE: 2/17/14  
SCALE: N.T.S.  
DWG. BY: JK  
CHK. BY: LFS  
DRAWING NO.: FL-16853.7  
SHEET 1 OF 6



R:\Clients\Doers PERMANENT\Florida Product Approvals\FL-16853 Windows - Horizontal Sliders\C - Drawings\FL-16853 (2014)\FL-16853.7-12.dwg, 2.7

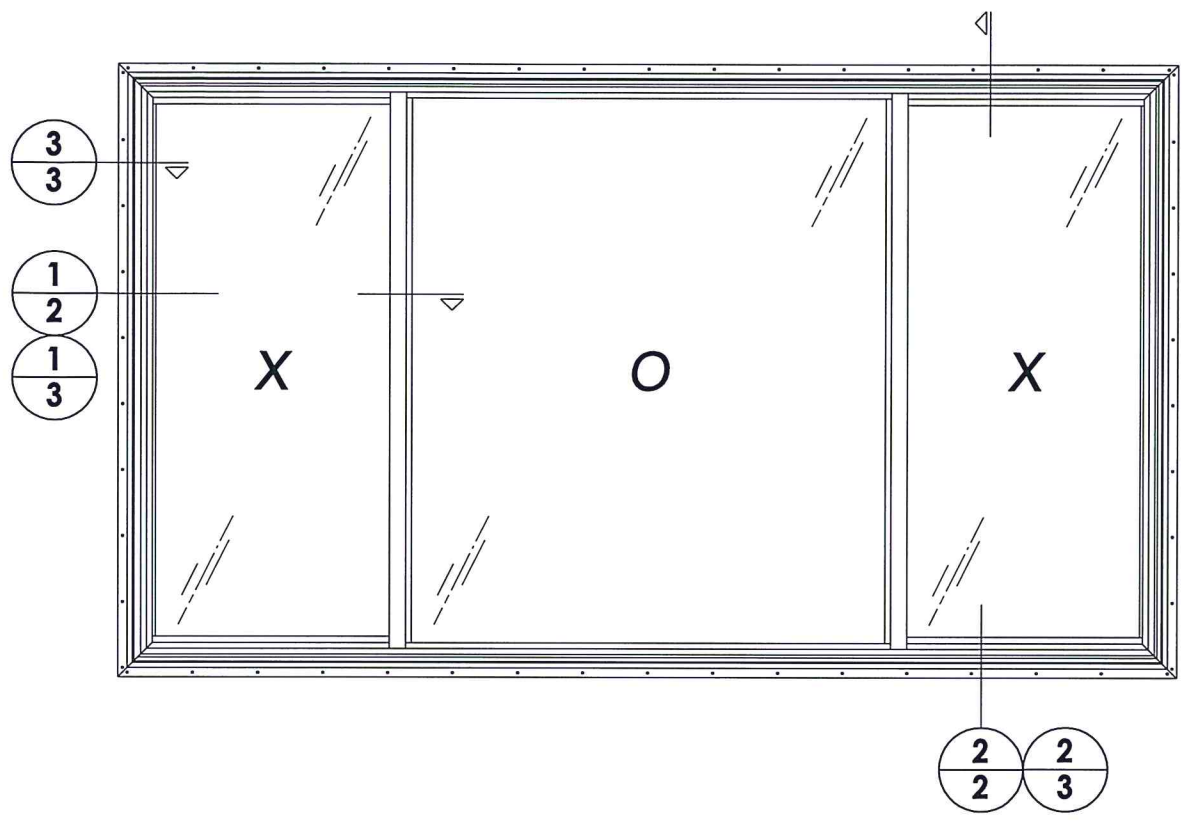

Note:  
 1. Lock and keeper located 7" from each end of lock/meeting stile.  
 2. Metal roller assembly located 2" from each end of the bottom rail.  
 3. Anti-lift secured to head with (6) #6 x 1/2" PPH SMS.

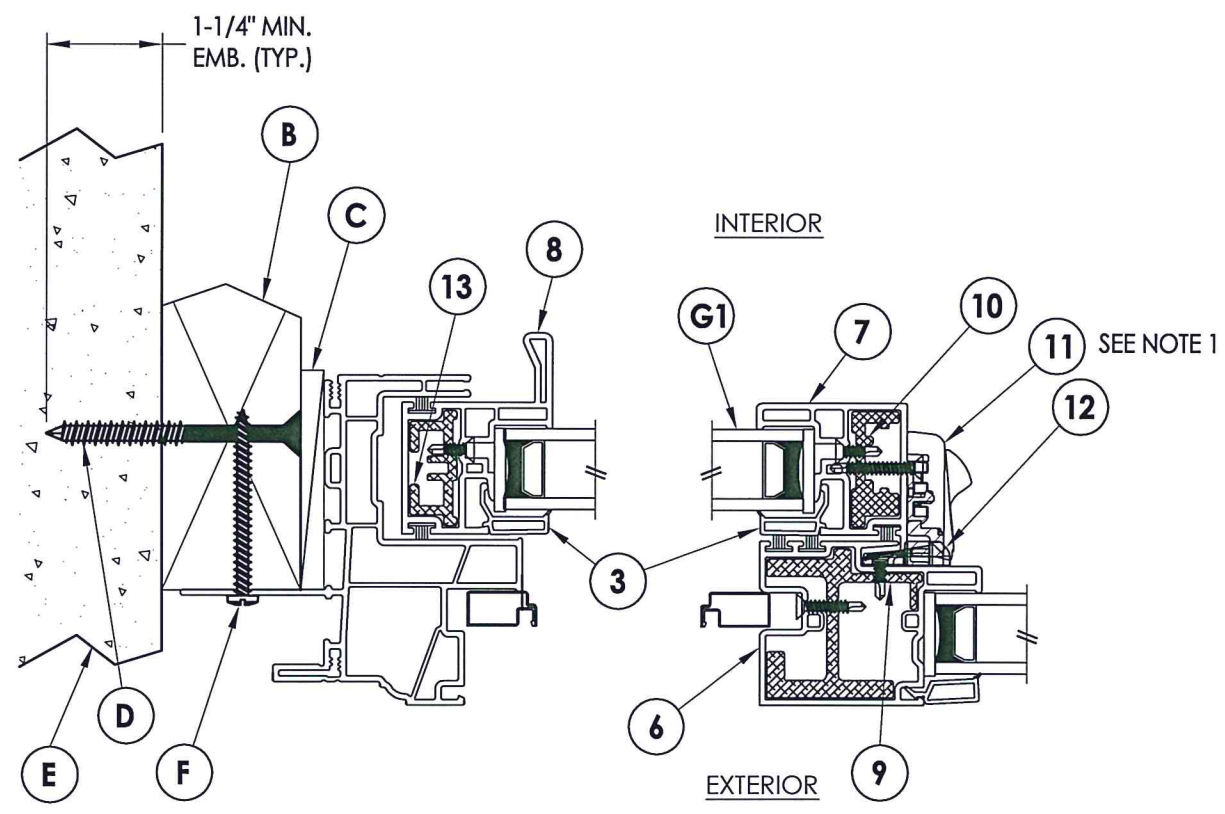

**1 HORIZONTAL CROSS SECTION**  
**2 2X Buck Masonry Construction**

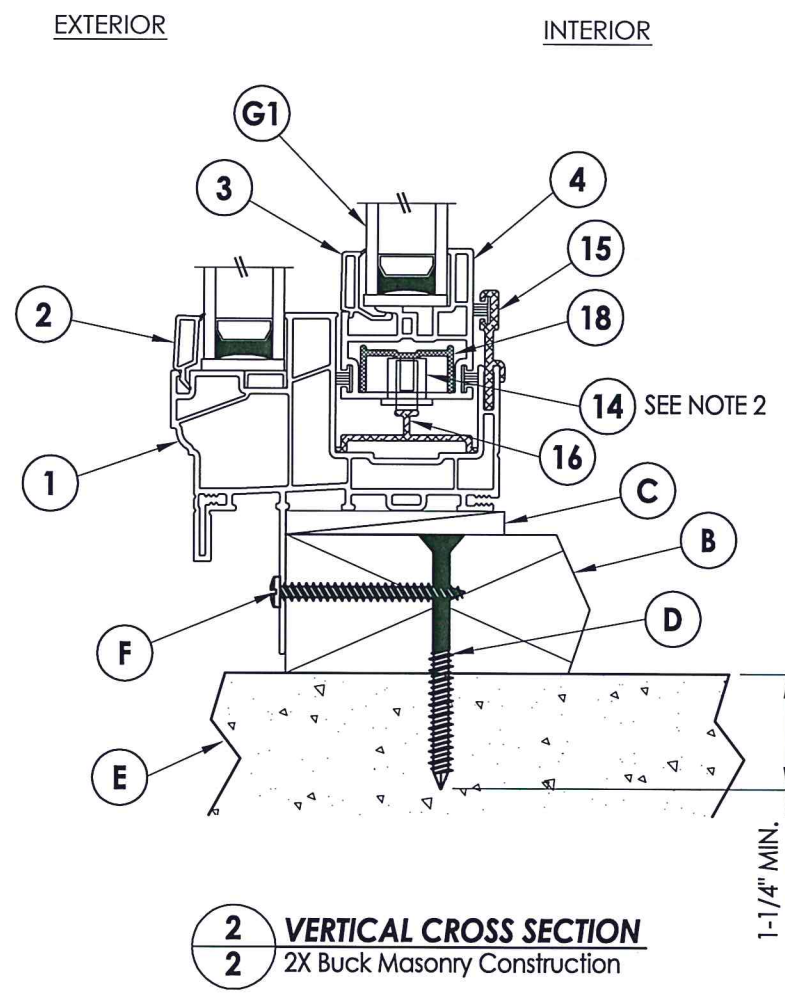
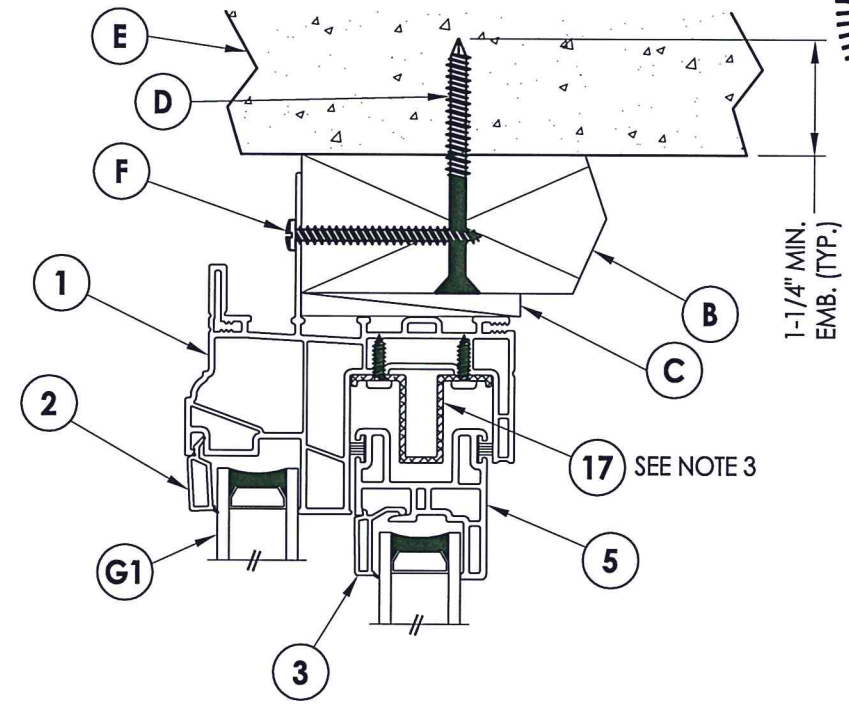

**2 VERTICAL CROSS SECTION**  
**2 2X Buck Masonry Construction**

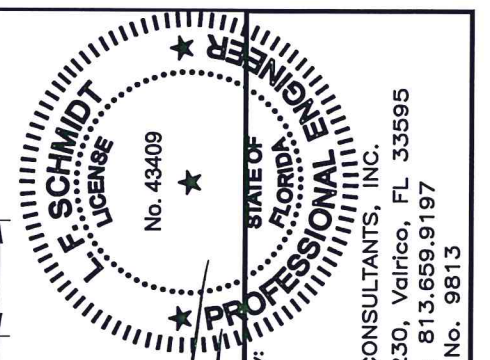

Documents Prepared By:  
 Lyndon F. Schmidt  
 P.E. No. 43409

**RW** BUILDING CONSULTANTS, INC.  
 P.O. Box 230, Valrico, FL 33595  
 Phone No.: 813.659.9197  
 FBPE C.A. No. 9813

PRODUCT:	Doers	
PART OR ASSEMBLY:	VERTICAL & HORIZONTAL CROSS SECTIONS	
NO.	DATE	BY
1	6/25/15	LFS
UPDATE TO 5TH ED. (2014) FBC		
REVISIONS		
DATE:	2/17/14	
SCALE:	N.T.S.	
DWG. BY:	JK	
CHK. BY:	LFS	
DRAWING NO.:	FL-16853.7	
SHEET	2 OF 6	

R:\Clients\Doers PERMANENT\A - Florida Product Approvals\FL-16853 Windows - Horizontal Sliders\C - Drawings\FL-16853 (2014)\FL-16853.7-12.dwg, 3.7

**Note:**

1. Lock and keeper located 7" from each end of lock/meeting stile.
2. Metal roller assembly located 2" from each end of the bottom rail.
3. Anti-lift secured to head with (6) #6 x 1/2" PPH SMS.

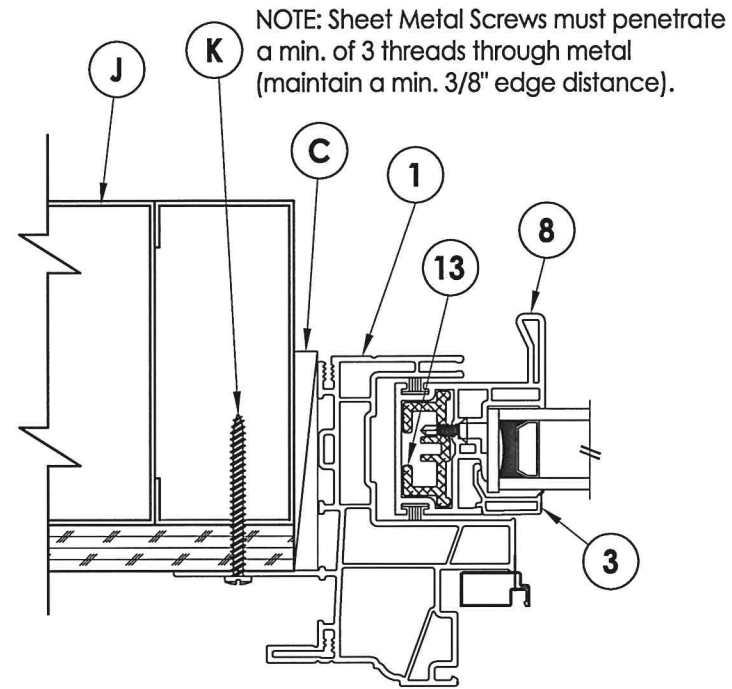

**3 HORIZONTAL CROSS SECTION**  
3 Shown w/ Steel Stud Framing Option

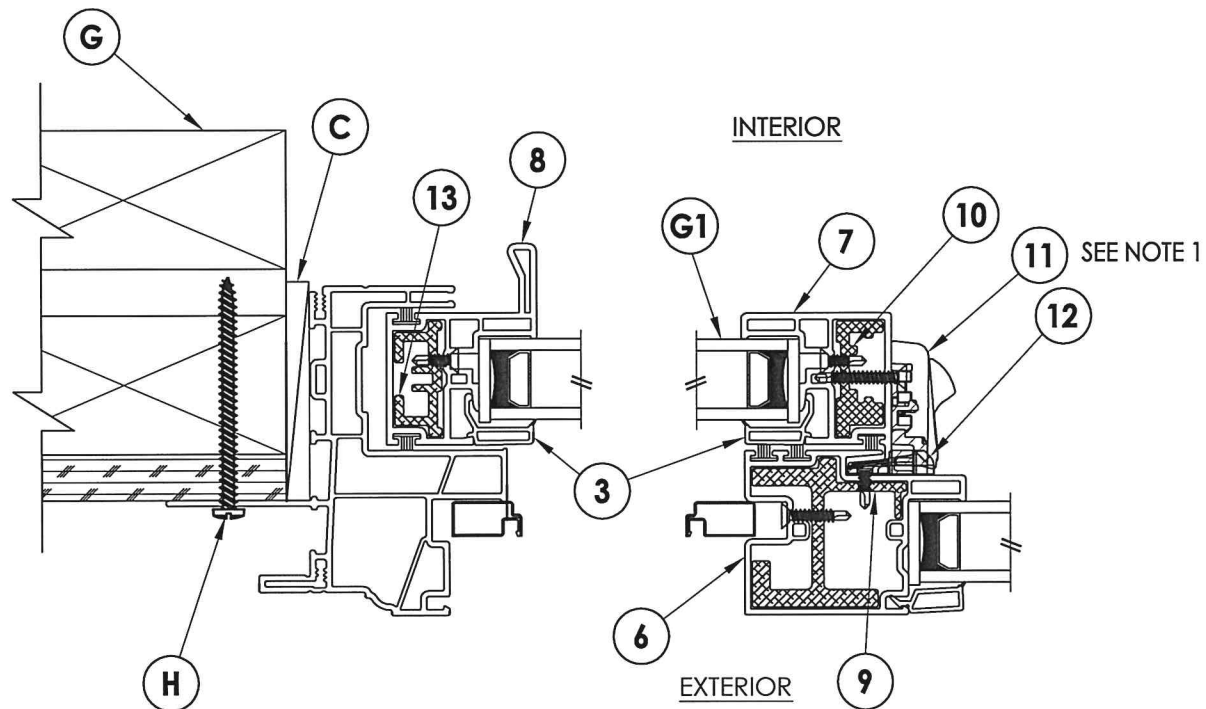

**1 HORIZONTAL CROSS SECTION**  
3 2X Stud Construction

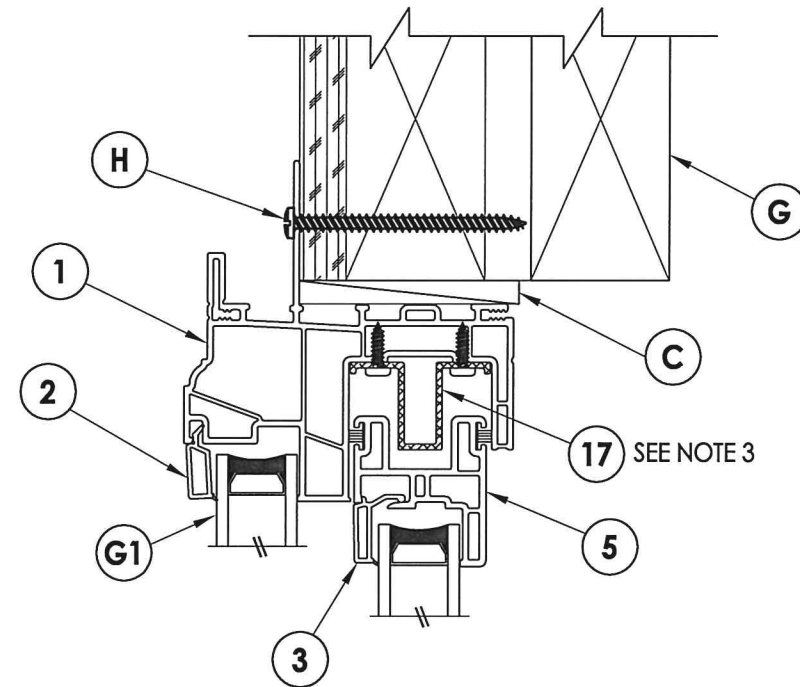

EXTERIOR

INTERIOR

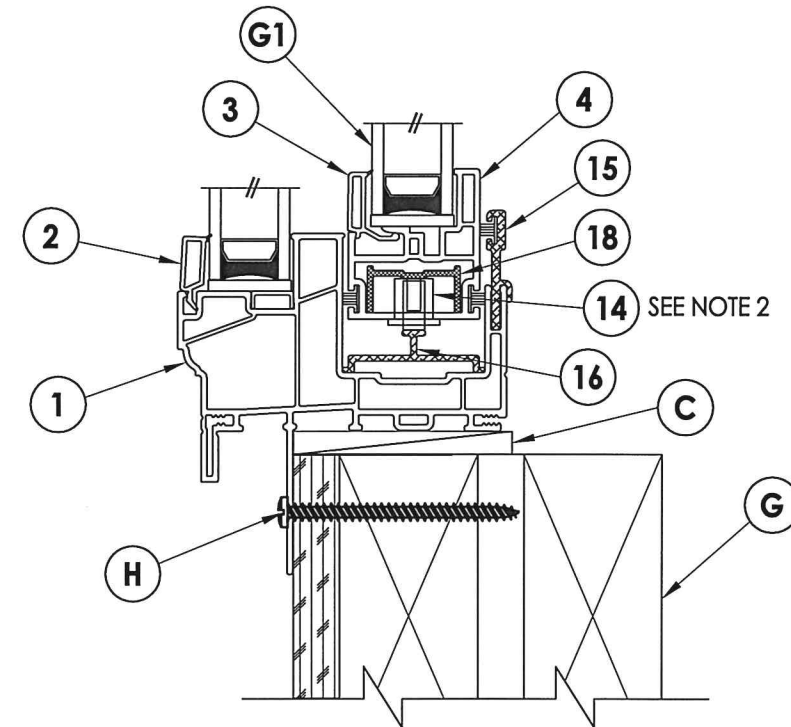

**2 VERTICAL CROSS SECTION**  
3 2X Stud Construction

*F. Schmidt*  
 9.22.14

Documents Prepared By: Lyndon F. Schmidt  
 P.E. No. 43409

**R.W.** BUILDING CONSULTANTS, INC.  
 P.O. Box 230, Valrico, FL 33595  
 Phone No.: 813.659.9197  
 FBPE C.A. No. 9813

PRODUCT:	Doers		
PART OR ASSEMBLY:	VERTICAL & HORIZONTAL CROSS SECTIONS		
NO.	DATE	BY	REVISIONS
1	6/25/15	LFS	UPDATE TO 5TH ED. (2014) FBC
DATE: 2/17/14			
SCALE: N.T.S.			
DWG. BY: JK			
CHK. BY: LFS			
DRAWING NO.: FL-16853.7			
SHEET 3 OF 6			



R:\Clients\Doers PERMANENT\Florida Product Approvals\FL-16853 Windows - Horizontal Sliders\C - Drawings\FL-16853.7-12.dwg, 4.7

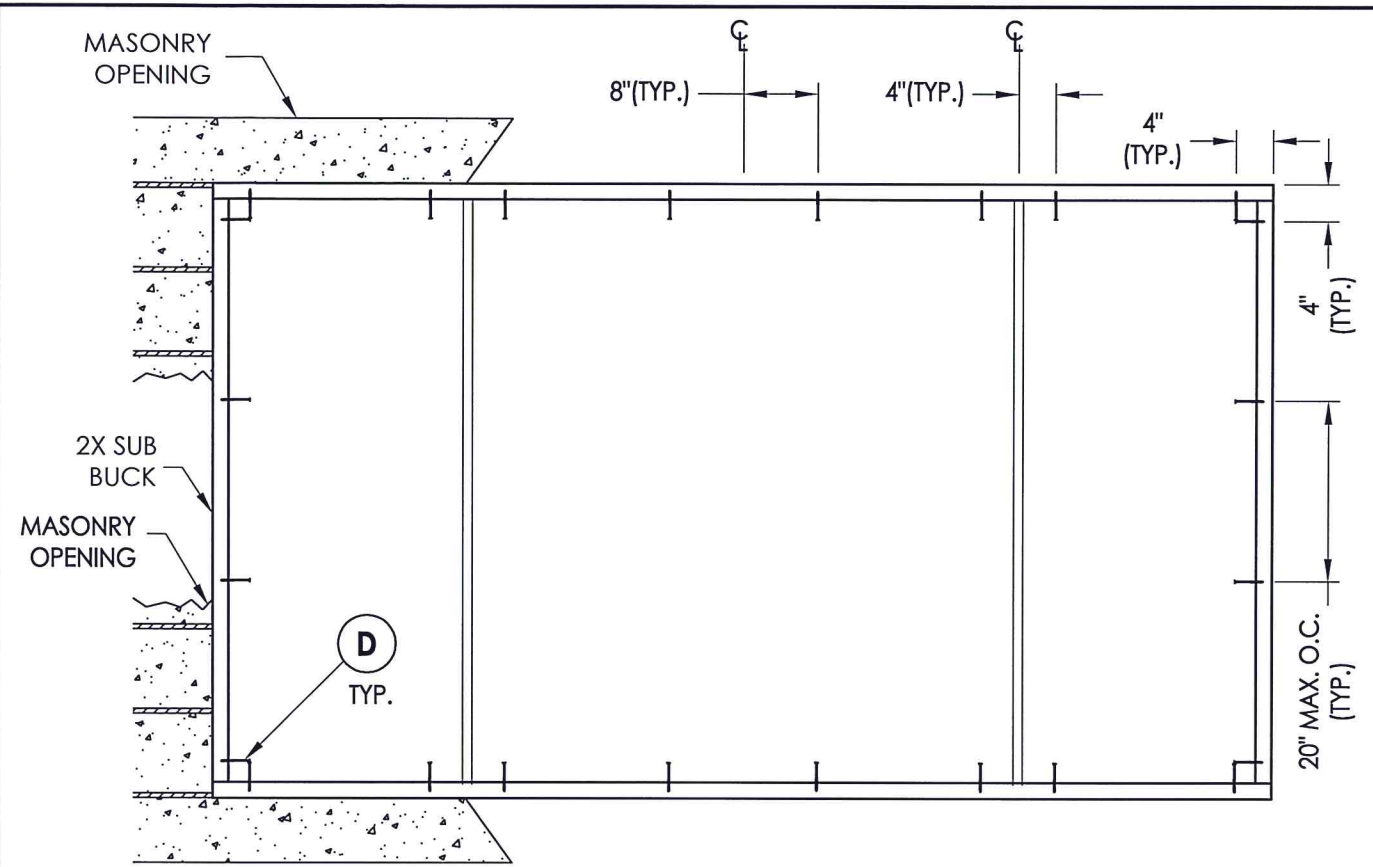

**BUCK ANCHORING**

2X/STEEL STUD FRAMING TO BE DESIGNED BY THE ENGINEER OR ARCHITECT OF RECORD BASED ON WIND LOADS AND THE CLADDING BEING USED.

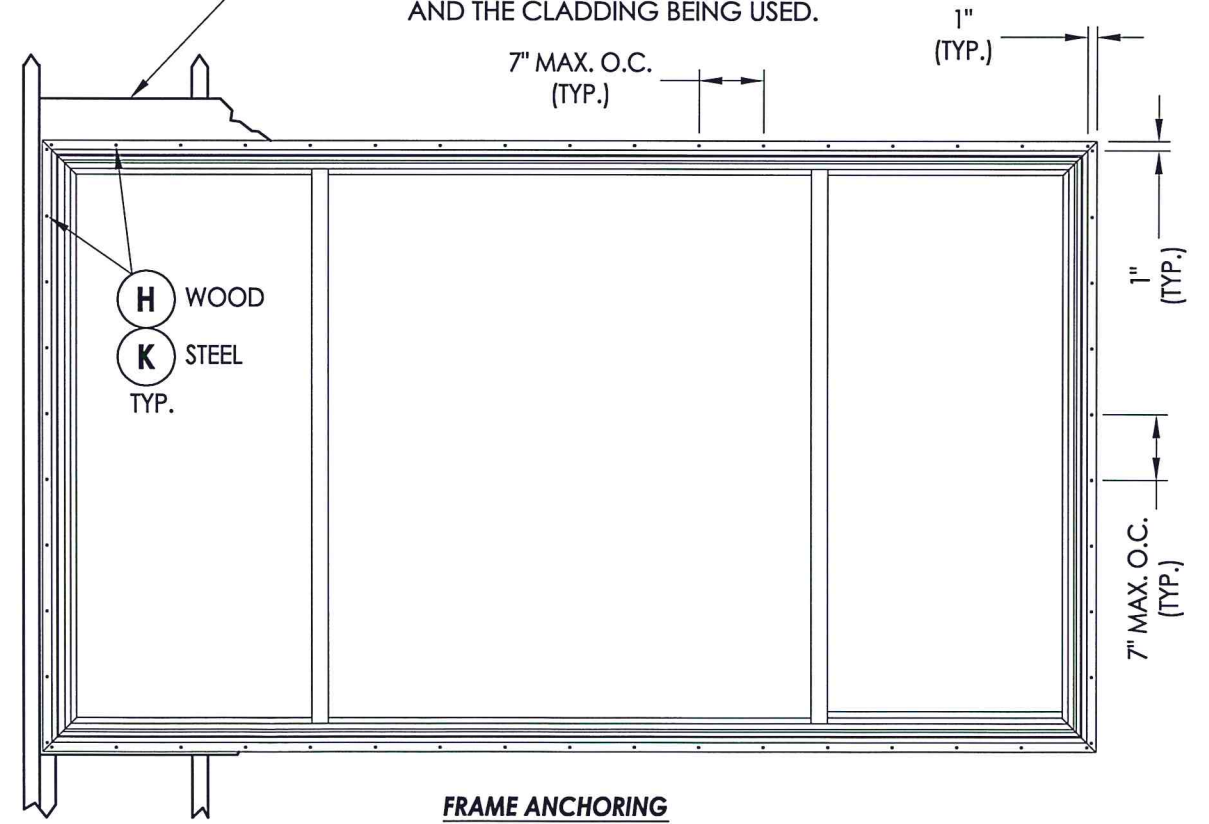

**FRAME ANCHORING**  
Stud Construction

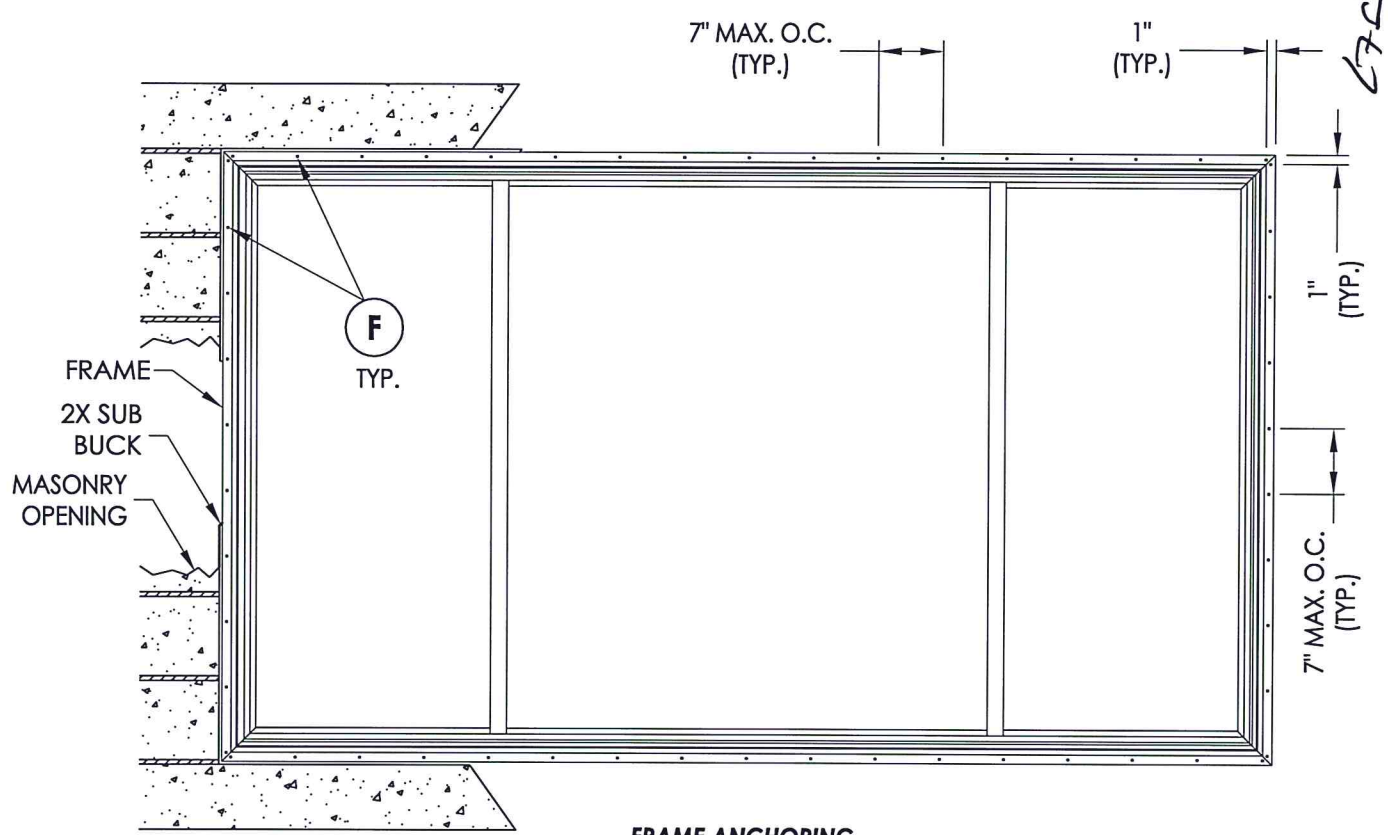

**FRAME ANCHORING**  
2X Buck Masonry Construction

**CONCRETE ANCHOR NOTES:**

- Concrete anchor locations at the corners may be adjusted to maintain the min. edge distance to mortar joints.
- Concrete anchor locations noted as "MAX. ON CENTER" must be adjusted to maintain the min. edge distance to mortar joints, additional concrete anchors may be required to ensure the "MAX. ON CENTER" dimension are not exceeded.
- Concrete anchor table:

ANCHOR TYPE	ANCHOR SIZE	MIN. EMBEDMENT	MIN. CLEARANCE TO MASONRY EDGE	MIN. CLEARANCE TO ADJACENT ANCHOR
ITW TAPCON®	1/4"	1-1/4"	2"	4"
ELCO ULTRACON®	1/4"	1-1/4"	1"	4"

**WOOD SCREW INSTALLATION NOTES:**

- Maintain a minimum 5/8" edge distance, 1" end distance, & 1" o.c. spacing of wood screws to prevent the splitting of wood.

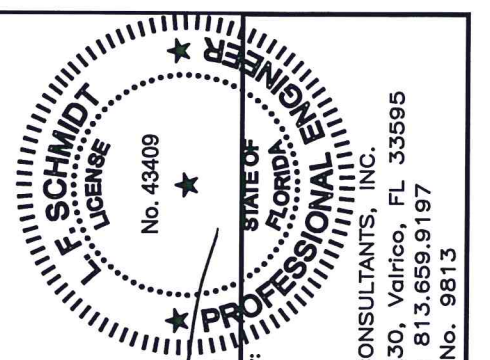

Documents Prepared By:  
Lyndon F. Schmidt  
P.E. No. 43409

**RW** BUILDING CONSULTANTS, INC.  
P.O. Box 230, Valrico, FL 33595  
Phone No.: 813.659.9197  
FBPE C.A. No. 9813

PRODUCT:	Doers
PART OR ASSEMBLY:	BUCK & FRAME ANCHORING

NO.	DATE	BY	REVISIONS
1	6/25/15	LFS	UPDATE TO 5TH ED. (2014) FBC

DATE: 2/17/14  
SCALE: N.T.S.  
DWG. BY: JK  
CHK. BY: LFS  
DRAWING NO.: FL-16853.7  
SHEET 4 OF 6

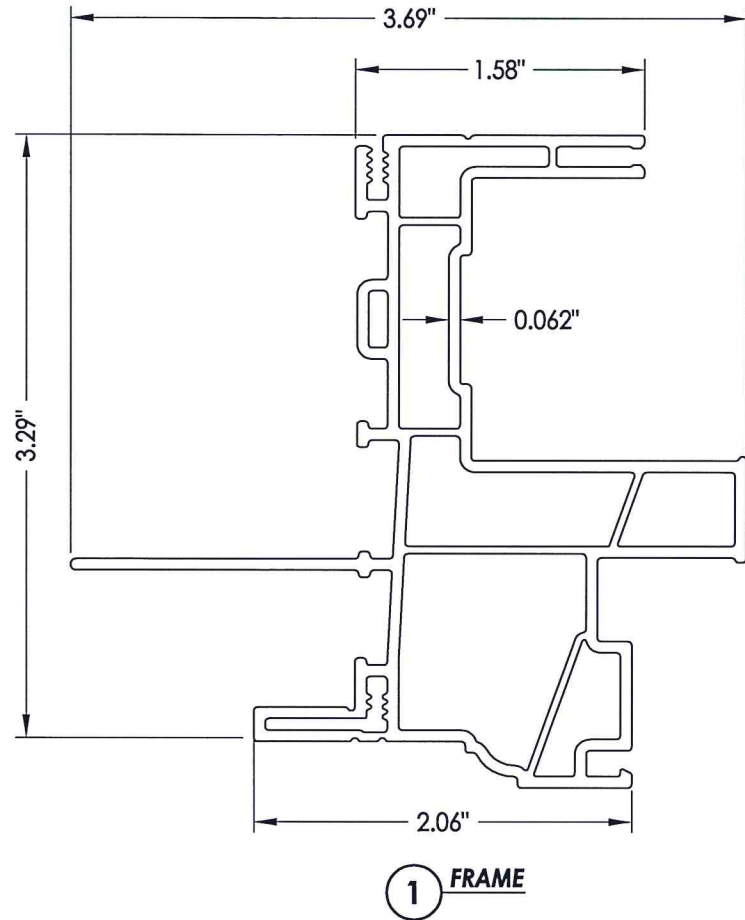

**1** FRAME

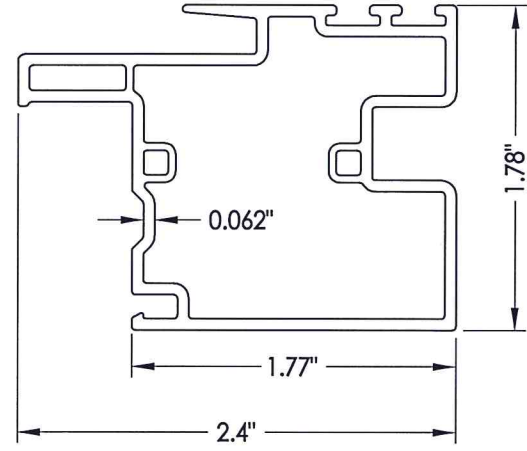

**6** MEETING STILE

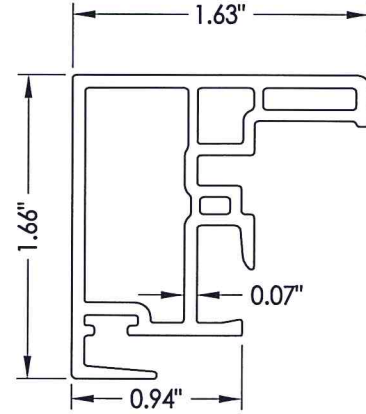

**7** LOCK STILE

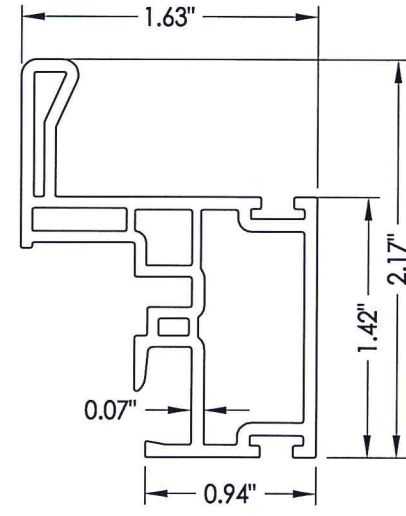

**8** HANDLE STILE

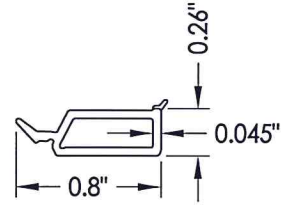

**2** GLAZING BEAD

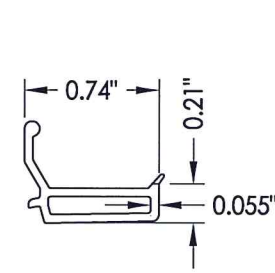

**3** GLAZING BEAD

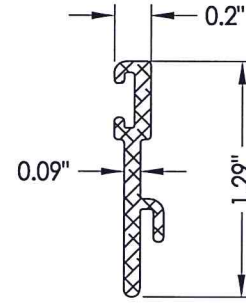

**15** SILL RISER

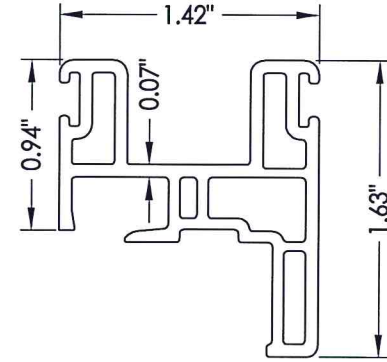

**5** TOP RAIL

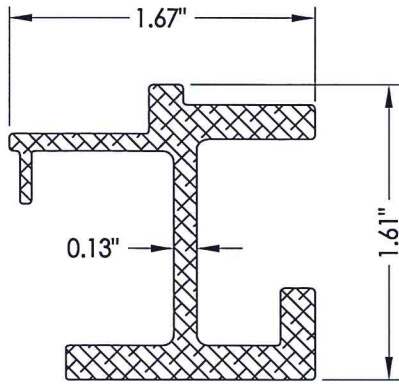

**9** MEETING STILE REINFORCEMENT

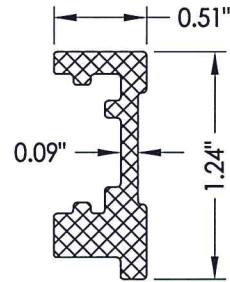

**10** LOCK STILE REINFORCEMENT

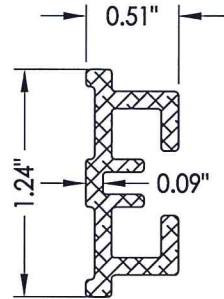

**13** HANDLE STILE REINFORCEMENT

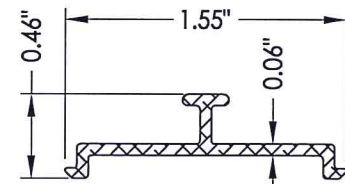

**16** ROLLER TRACK

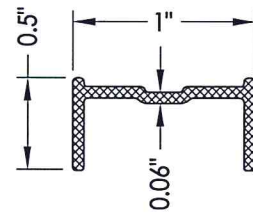

**18** BOTTOM RAIL REINFORCEMENT

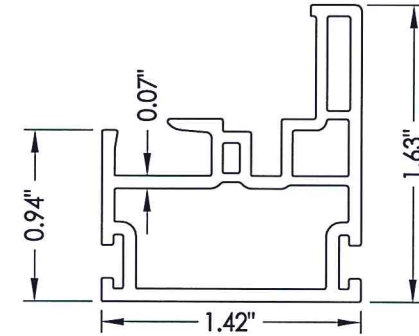

**4** BOTTOM RAIL

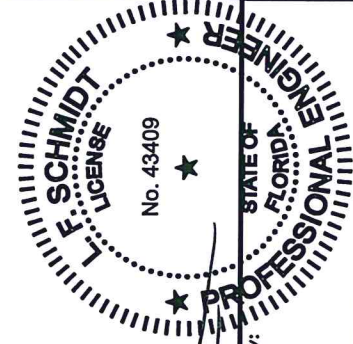

Documents Prepared By:  
Lyndon F. Schmidt  
P.E. No. 43409

**R.W.** BUILDING CONSULTANTS, INC.  
P.O. Box 230, Valrico, FL 33595  
Phone No.: 813.659.9197  
FBPE C.A. No. 9813

PRODUCT: Doers		PART OR ASSEMBLY: COMPONENTS										
DATE: 2/17/14		SCALE: N.T.S.										
DWG. BY: JK		CHK. BY: LFS										
DRAWING NO.: FL-16853.7		REVISIONS										
SHEET 5 OF 6		<table border="1"> <thead> <tr> <th>NO.</th> <th>DATE</th> <th>BY</th> </tr> </thead> <tbody> <tr> <td>1</td> <td>6/25/15</td> <td>LFS</td> </tr> <tr> <td></td> <td>UPDATE TO 5TH ED. (2014)</td> <td>FBC</td> </tr> </tbody> </table>		NO.	DATE	BY	1	6/25/15	LFS		UPDATE TO 5TH ED. (2014)	FBC
NO.	DATE	BY										
1	6/25/15	LFS										
	UPDATE TO 5TH ED. (2014)	FBC										



**BILL OF MATERIALS**

ITEM #	DESCRIPTION	MATERIAL
B	2X BUCK (SG >= 0.42)	WOOD
C	1/4" MAX. SHIM SPACE	-
D	1/4" X 2-3/4" PFH ELCO OR ITW CONCRETE SCREW	STEEL
E	MASONRY - 3,000 PSI MIN. CONCRETE CONFORMING TO ACI 301 OR HOLLOW BLOCK CONFORMING TO ASTM C90	CONCRETE
F	#10 X 2" PPH SMS (1-3/4" MIN. EMBEDMENT)	STEEL
G	2X STUD (SG >= 0.42)	WOOD
H	#10 X 2-1/2" PPH SMS (1-3/4" MIN. EMBEDMENT)	STEEL
J	STEEL STUD Min. Thk .033" (ASTM A653 GRADE 33 Fy=33 ksi min., Fu=45 ksi min.)	STEEL
K	#10 PPH SELF-DRILLING SMS	STEEL
1	EXTRUDED VINYL FRAME (437)*	RIGID PVC
2	EXTRUDED VINYL GLAZING BEAD (736A)*	RIGID PVC
3	EXTRUDED VINYL GLAZING BEAD (425A) *	RIGID PVC
4	BOTTOM RAIL (424B)*	RIGID PVC
5	TOP RAIL (478)*	RIGID PVC
6	MEETING STILE (477)*	RIGID PVC
7	LOCK STILE (476)*	RIGID PVC
8	HANDLE STILE (475B)*	RIGID PVC
9	MEETING STILE REINFORCEMENT	6063 - T5 ALUM
10	LOCK STILE REINFORCEMENT	6063 - T5 ALUM
11	SASH LOCK	-
12	KEEPER	-
13	HANDLE STILE REINFORCEMENT	6063 - T5 ALUM
14	ROLLER (TRUTH #2433-1000)	-
15	SILL RISER	6063 - T5 ALUM
16	ROLLER TRACK	6063 - T5 ALUM
17	ANTI-LIFT ALUMINUM	6063 - T5 ALUM
18	BOTTOM RAIL REINFORCEMENT	6063 - T5 ALUM
20	WEATHERSTRIP (.187" X .290")	-

\* THE APPROVED WHITE RIGID PVC EXTERIOR EXTRUSIONS FOR WINDOWS ARE TO BE PRODUCED BY EXTRUDERS LICENSEES IN "AAMA CERTIFICATION PROGRAMS FOR RIGID PVC EXTRUSIONS".

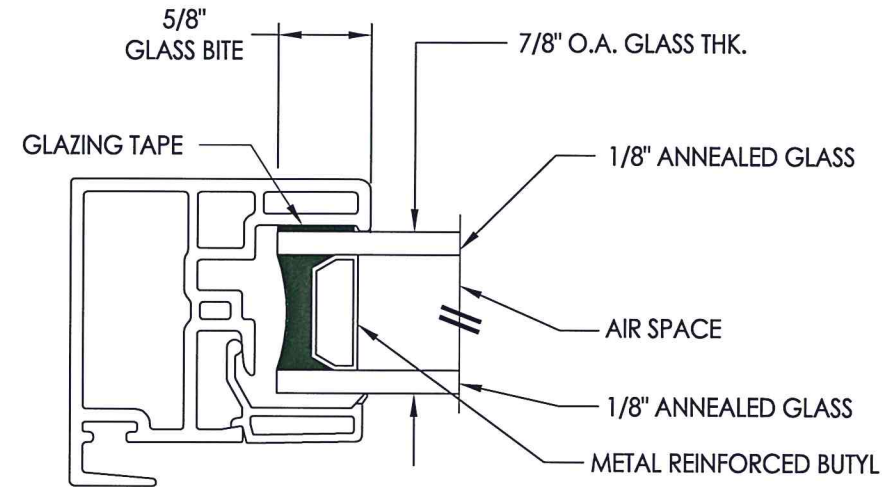

**G1 GLAZING DETAIL**

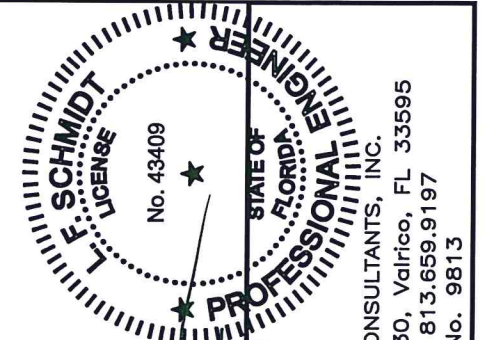

Documents Prepared By:  
Lyndon F. Schmidt  
P.E. No. 43409

R.W. BUILDING CONSULTANTS, INC.  
P.O. Box 230, Vairico, FL 33595  
Phone No.: 813.659.9197  
FBPE C.A. No. 9813

PRODUCT:	Doers
PART OR ASSEMBLY:	BILL OF MATERIALS AND GLAZING DETAILS

NO.	DATE	BY	REVISIONS
1	6/25/15	LFS	UPDATE TO 5TH ED. (2014) FBC

DATE:	2/17/14
SCALE:	N.T.S.
DWG. BY:	JK
CHK. BY:	LFS
DRAWING NO.:	FL-16853.7
SHEET	6 OF 6